

## Content

1. Lifting points "Lifting eye bolt Z711/..."
2. Intended use
3. Instructions for use
4. Restrictions on use
5. Mounting instructions
6. Maintenance, checks
7. EC Declaration of Conformity



**Lifting eye bolt**

## 1. Lifting points "Lifting eye bolt, high strength Z711/..."

These lifting points are designed for use in accordance with these operating instructions and the respective national regulations governing the lifting and holding of loads. They may only be brought into operation after the instructions for use have been read and understood.

The instructions for use must be made available to the user until such time as the lifting points are taken out of service. The instructions are subject to a continuous improvement process and are only valid in their latest version.

The instructions for use are available to download at [www.hasco.com](http://www.hasco.com).

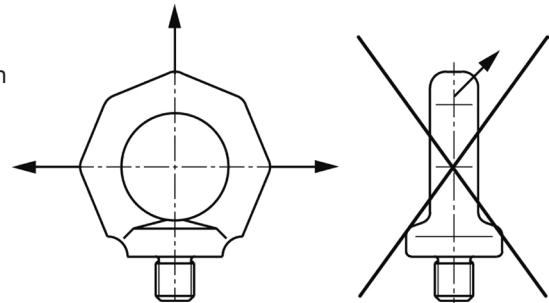



Fig. 1: permitted

Fig. 2: not permitted

Lifting method	No.	Thread [mm]	Tightening torque [Nm]	Load capacity [kg]	
					
	Z711/10	<b>M 10</b>	can be tightened manually	1000	250
	12	<b>M 12</b>		1600	400
	14	<b>M 14</b>		3000	750
	16	<b>M 16</b>		4000	1000
	20	<b>M 20</b>		6000	1500
	24	<b>M 24</b>		8000	2000
	30	<b>M 30</b>		12000	3000

## 2. Intended use

### Load

The load capacity is as per the load limit table in the specified directions of tension – see Fig. 1.

### Admissible operating temperature

-40°C to +200°C – If used at above 200°C, the load capacity must be reduced on a permanent basis:  
 +200°C to +300°C (minus 10%), +300 C bis +400°C (minus 25%)  
 Use at temperatures below -40°C or above +400°C is not permitted.

## 2. Intended use

### **Impacts and vibration**

Shock loads or vibrations can lead to unintended loosening and must be avoided. If this is not possible, a liquid thread-locking agent must be used in accordance with the manufacturer's instructions.

### **Additional instructions**

If the lifting eye bolt is used on an alternative basis for transporting different components, the next largest thread diameter must be used.

If used with multi-strand end attachments, the corresponding rules must be observed.

## 3. Instructions for use

- Lifting points are to be used only by competent, authorized personnel.
- A visual inspection must be performed before first usage (see maintenance instructions).
- Check for evidence of damage prior to each use.
- In the event of a malfunction, the lifting point must be taken out of service immediately and undergo maintenance.
- Lifting points must be kept dry and clean.
- Load only in the specified direction (see Fig. 1) with the load capacity as per the table.
- Prior to each use, ensure that the lifting point is hand-tightened.
- Pay attention to any load obstructions as per the restrictions on use.
- The end attachment inserted in the ring (e.g. hook) must be able to move freely within the ring.
- The lifting points are not designed to be rotated under load.

### **Please note:**

- Do not overload lifting points. A falling load can cause injury and/or death.
- Damaged lifting points (see maintenance instructions) can fail under normal operating conditions – the load may fall. These lifting points must not be used.

## 4. Restrictions on use

**Under abnormal operating conditions (see above), lifting points can only be used with limitations.**

- Lifting points must not be exposed to acids and alkalis or their vapours.  
Please contact our technical service regarding use in environments containing chemicals.
- The lifting points must not be loaded via corners or edges etc.
- People must not be lifted.
- Loads may not be lifted or transported if people are present within the danger zone of the load.

## 5. Mounting instructions

**Installation may only be carried out by a competent person.**

- The overall system on which the lifting points are mounted must meet the requirements of Directive 2006/42/EC.
- No changes may be made to the delivered item. It is not permitted, for example, to perform welding, heat treatment or other surface treatments that damage the material (e.g. galvanic zinc coating), or to shorten the screw.
- Only mount defect-free lifting points.
- Check used lifting points prior to installation as per the maintenance instructions.
- The lifting points must be easily recognisable on the load, e.g. through colour marking.
- When selecting the configuration, make sure that no incorrect loading can result, for example if:
  - free alignment is not possible in the direction of tension
  - the direction of tension is not within the specified range as per the table
- Select the arrangement of the lifting points to ensure symmetric loading, with the centre of gravity beneath the lifting point(s).
- The base material of the object, on which the lifting points are to be mounted, must be sufficiently strong to absorb the induced forces without deformation.
- Lifting points with a sufficient load capacity must be selected - see load capacity table.
- The surface to which the lifting point is to be screwed must be flat and be at least the diameter of the lower face of the lifting point. The threaded hole must be in the centre of the surface, at right angles to it and sufficiently deep for the screw to be fully screwed in (blind holes).
- The minimum screw-in length is as follows: 1 x M in steel (M = thread size e.g. M20 = 20mm) 1.25 x M in cast steel, 2 x M in aluminium, 2.5 x M in low-strength light metals  
For light metals, non-ferrous metals and grey cast iron, the thread allocation must be selected in such a way that the thread load capacity meets the requirements of the base material.
- The number and arrangement of lifting points on the load must be selected in such a way that the load is carried safely and cannot unpredictably change its position during transport.
- The threaded hole must be cleaned prior to screwing in the lifting point.
- If necessary (e.g. in the event of vibrations), use a liquid thread-locking agent, observing the manufacturer's instructions.

The lifting points must be attached to the load in the following manner,

- so that they can be accessed easily and without hindrance for attaching and detaching the end attachment.
- so that no danger points (e.g. crushing points, shearing points, catching or impact points) can arise that could endanger or obstruct the lifting point and/or the transport of the load.
- so that the forces to be introduced can be absorbed by the base material of the load without deformation.
- to avoid inadmissible stressing, e.g. due to eccentric force application and an uneven load distribution, paying consideration to the centre of gravity (EN 818-6).
- so that the lifting point is not obstructed by other structural parts and so that damage through deflection around sharp edges is avoided.
- Screw the lifting point into the anchorage system until the lower face is fully in contact with the surface.
- If used with through holes, the lifting point must be fixed with a nut (0.8xd) which is fully and firmly bolted on. If the thread is long enough, the use of a washer is recommended.
- Hand-tighten the lifting point.
- Do not use an extension during assembly.

## 6. Maintenance, Checks

- Lifting points must be checked at least once a year by a competent person. The time period may be shorter depending on the operating conditions. For frequent use, we recommend carrying out a crack test every 2 years.
- The parts must be free from oil, dirt and rust for the regular inspection and crack test. Suitable cleaning methods are those that do not overheat, do not conceal surface defects and do not cause hydrogen embrittlement or stress corrosion cracking.
- During inspections, the lifting point must be checked for damage that could impair its safety and function. e.g.:
  - fracture, notches, cracks, deformation
  - inadmissible heat influence
  - abrasion or corrosion of more than 10% of the cross section

**If there is any doubt as to the function and/or safety of the lifting point, it is essential to stop using it.**

## 7. EC Declaration of Conformity (No.: Lastaufnahmemittel\_EN\_EG-2019-04)

This declaration of conformity is issued under the sole responsibility of:

**HASCO Hasenclever GmbH + Co KG, Römerweg 4, D-58513 Lüdenscheid, +49 2351 957-0, info@hasco.com**

### Object of the declaration:

References to the relevant harmonised standards are taken as a basis or references to the specifications for which conformity is declared: Reference number of the standard

No.	EN ISO 12100	EN 1677-1	DIN 580	DIN 582	DGUV 100-500 (BGR 500, 2.8)
Z70/..., Z701/...	X				
Z710/...	X		X		X
Z711/...	X	X			X
Z7120/...	X			X	X
Z715/...	X	X			
Z721/...	X				
Z725/...	X	X			

The object of the declaration described above complies with the relevant Community harmonisation legislation: 2006/42/EG

Name and address of the person authorised to compile the technical documentation:

Stefan Fritsch,  
Team leader  
(Name, function)

Römerweg 4, D-58513 Lüdenscheid  
(Address)

Lüdenscheid, 2019-04-08  
(Place and date of issue)

Andre Brandt  
Executive Vice President Mould Base Technology  
(Name, function)

Römerweg 4, D-58513 Lüdenscheid  
(Address)